

**PATIENT LIFT  
CAMLOCK UPGRADE KIT  
1052250**

**Installation, Assembly  
and Operating Instructions**

**SAFETY SUMMARY**

The following recommendations are made for the safe installation of the Patient Lift Camlock Upgrade Kit.

**WARNING**

Check ALL parts for shipping damage and test before using. In case of damage, DO NOT use. Contact the carrier/dealer for further instructions.

Make certain all screws and nuts are tight at all times.

Kit Includes the following:

Description	Quantity
Bronze Washer	1
Camlock Assembly	1
Button Head Screw	1
Locknut	1
1/4-inch Washer	1

Tools Required:

- One (1) Phillips Screwdriver
- One (1) Allen Head Wrench
- One (1) C-Clamp

**LIFT DISASSEMBLY (FIGURES 1 and 2)**

1. Turn and lift up the mast assembly to unlock it from the base (FIGURE 1).
2. Remove the mast assembly from the base.
3. Using the shifter handle, close the legs of the base (FIGURE 1).

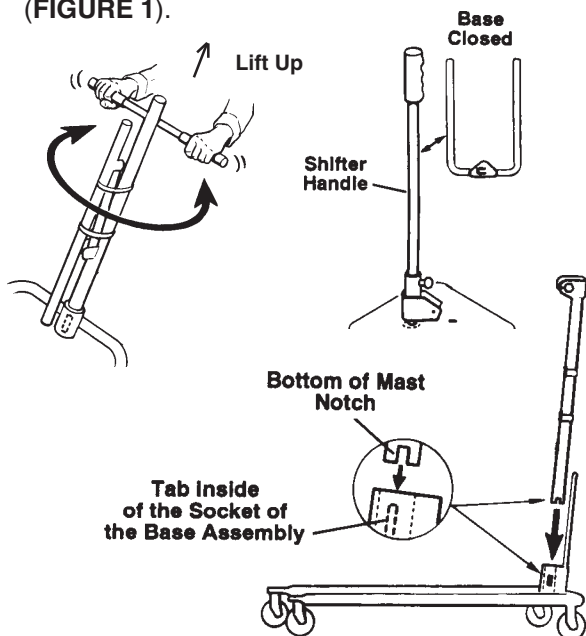

**FIGURE 1 - REMOVING MAST AND CLOSING LEGS**

4. Loosen the thumb screw that secures the base shifter handle into the cam lock assembly at the back of the base (FIGURE 2).
5. Remove the base shifter handle (FIGURE 2).
6. Lift up on the socket assembly (closed end of the base) and lean the base against a workbench with the socket assembly (closed end of the base) at the TOP.
7. Remove the two (2) screws that secure the rear cover plate to the socket assembly (FIGURE 2).
8. Remove the rear cover plate (FIGURE 2).

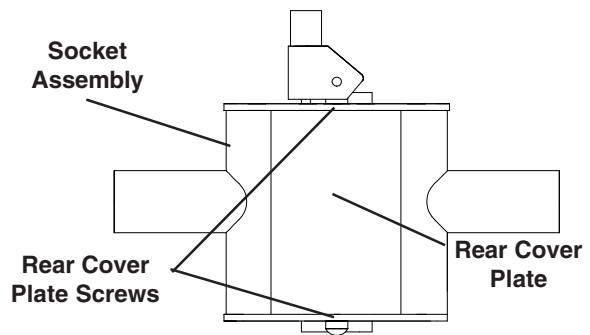
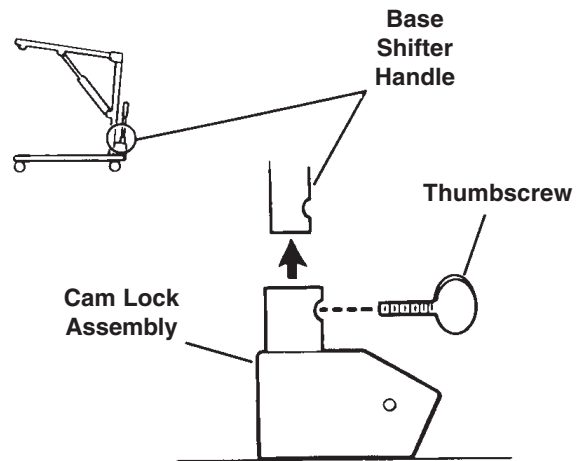

**FIGURE 2 - REMOVING SHIFTER HANDLE AND REAR COVER PLATE**

**INSTALLATION (FIGURE 3)**

1. Position C-Clamp on both sides of the socket assembly with the adjustable portion of the C-clamp against the bottom of the cam as shown in FIGURE 3.

**NOTE:** The upper portion of the C-Clamp will lodge against the the cam on the inside of the socket assembly only after the adjustable portion of the C-clamp has been engaged.

### CAUTION

Make sure the C-Clamp is securely lodged against the socket assembly and cam BEFORE removing the camlock.

2. SLOWLY tighten the C-clamp and push the cam UP to release the camlock.
3. Remove the roll pin that secures the cam to the cam lock and discard.

**NOTE: The Button Head Socket Screw, washer and locknut replace the roll pin.**

4. Remove the camlock and washer.

**NOTE: Visually inspect the washer and roll pin below the cam spring for wear and replace if necessary.**

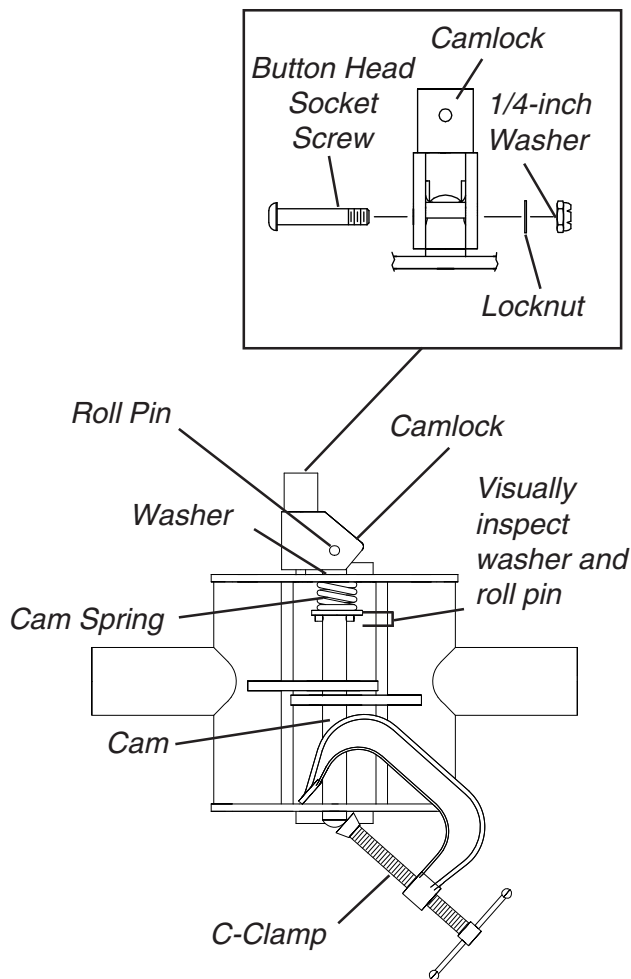

FIGURE 3 - INSTALLATION

6. Install the new bronze washer over the cam.

### WARNING

For proper operation of the patient lift base the camlock **MUST** be pointing to the **RIGHT** when standing **BEHIND** the patient lift.

7. With the camlock pointing to the right, install the camlock onto the cam.
8. Line up the holes of the cam and camlock and insert the button head socket screw through the holes.
9. Install the 1/4-inch washer over the button head socket screw.
10. Securely tighten the button head screw and washer with the locknut provided in the kit.
11. SLOWLY, release the C-Clamp from the cam.

### REASSEMBLY (FIGURES 1 and 2)

### WARNING

After reassembly and before use, make sure **ALL** bolts and screws are tightened securely.

1. Reinstall the cover plate onto the socket assembly with the screws provided.
2. Lower the base assembly onto all four (4) casters.
3. Re-Insert the base shifter handle into the cam lock assembly at the back of the base.
4. Align holes of the base shifter handle and cam lock assembly.
5. Tighten thumb screw to secure the base shifter handle in place.

**NOTE: This should prevent the base shifter handle from being removed.**

6. Match the notch at the **BOTTOM** of the mast assembly with the **TAB** **INSIDE** of the socket of the base assembly.
7. Re-insert the mast assembly into the sockets and onto the **TAB**.
8. Turn the mast assembly to make sure that the notch is locked on the **TAB** of the socket.

**NOTE: If the mast does not turn, the mast is centered and locked in place.**

### WARNING

Each time the mast is removed and returned to the socket of the base, the mast **MUST** be locked into the socket of the base assembly.

**INVACARE**  
Innovation in Health Care™

899 Cleveland Street ● P.O. Box 4028 ● Elyria, Ohio 44036-2125 ● Phone 1- (800) -333-6900